

the CALIFORNIA **MV** Collector 
NEWSLETTER

EDITOR: DAVE BALL *

2017

* VOL. XL, NUMBER 9



Andy Shyers' very nice Dodge M37 as seen last month at Tower Park. Andy joins the MVCC board as the VP for the 510-925 area codes. Ed.

CONTENTS

UPCOMING EVENTS	4, 5
MVCC STAFF	3,6,7,8
CLASSIFIEDS	14, 15
MVCC MEMBERSHIP APPLICATION	18

Wagon-Mistress Report Jo-Ann Lesser

September 2016 we all thought Tower Park Resort was in our past. As it turned out we were mistaken! The folks at Jellystone saw that we were a responsible group and welcomed us back! Yes, we were not as spread out as in years past, but in my opinion this tighter grouping made for a more social meet.

Jellystone has again, invited us back! They have blocked off **September 16-23, 2018** for our group to use campgrounds 2 and 3. They are in the process of renovating campground 1 and hopefully we will be able to use that area also. If campground 1 becomes available to us I would like to see the larger RV's and 5th wheels in campgrounds 1 and 3. Thus leaving campground 2 (in the middle) open for smaller RV's, tent trailers and tents. A map of the Jellystone Tower Park Resort can be found at Towerparkresorts.com.

The rates for 2018 which includes our 25% discount are as follows:

Red Carpet	\$89.25
Deluxe 30/50 amp	\$79.27
Pull Thru 30 amp	\$68.87
Back In 50 amp	\$58.25
Back In 30 amp	\$54.37
Cozy Cottage	\$142.98
Boo Boo Bungalow	\$161.74

Tower Park Resorts will begin taking **deposits** for 2018 starting **October 15, 2017**. The deposit will be 25% of your stay with another 25% due by July 1, 2018. The remaining balance will be due at time of check-in. Any site without deposit on **February 1, 2018** will be considered open and available. If you approached me with change of site requests at Tower this past event, those changes have been made and Tower Park has been notified. I am available if you have questions or concerns please don't hesitate to call or e-mail. **408.238.8277** or mamalesser@yahoo.com

AT THE FRONT



Dave Ball, MVCC President
(408) 805-0065
vought@msn.com

Hello Everyone:

It was great seeing so many of you at the Fall swapmeet at Tower Park. I had a great time once again and wish to thank everyone that made it and those that brought vehicles. As 2017 winds down, we are heading into the Holiday season. Next on the radar is Veterans Day celebrations. The Events section has several parades and other festivities to take your vehicles out and honor all of the men and women who have served in the United States military. I hope to see you out there.

Rather than duplicate what Joann has said in her Wagon Mistress Report, I would like to mention a few things discussed with the Tower Park management team. As you have read, we have been invited back next September. They have once again said they would relax some of the rules for our group. We can park for free up on the levy and there will be no fee for those that come out for the day. We can park tow trailers in the same area out by the front gate. If you were at Tower a couple weeks back, you would have seen that Jellystone has cleaned out Camp Ground One and construction was under way to put full hookups and new pads for pull throughs. There could be 30 available to the MVCC next September.

Many members have talked to me about Camp Petaluma. Plans are for the board to meet there in January. Before that I have plans to meet with Woody, the camp ground owner, and try to work out some of the concerns you the members have voiced to me and the board. This includes parking and the day-use fees. April 2018 will be here before you know it, so plan to get your vehicles ready. As you know, this is a driving meet, and I am sure there will be a couple rides like many enjoyed this past April.

If the fields are not soggy, we will have plenty of parking. We are talking about other solutions in case they are. We will need to address shuttle solutions if we have to park those without campsites offsite. KOA has offered the onsite RV storage lot to those with campsites for parking tow trailers. The "Dodge Boys" once again plan to gather next spring at Camp Petaluma. If you have a Dodge military vehicle, please plan on bringing it out. Stay tuned for more info as the details are worked out.

As always, if you would like to volunteer to help with the swapmeet or if you have a special skill like sign making let me or one of the VPs know. "Keep em Rolling, Floating and Flying."

Stay safe,
Dave Ball

**JAY'S
WWII JEEPS**

Specializing in vintage
WWII Willys MB/Ford GPW
vehicles and parts

1-844-WW2-JEEP

Jay Hinton | Napa, California USA | 1-844-992-5337 | jay@jaysww2jeeps.com

CLASSIC MILITARY AUTOMOTIVE

A division of
CMA North Bay

Shop: 1385-B CASS RD, SANTA ROSA, CA 95406
Mailing: PO BOX 6167, SANTA ROSA, CA 95406

Phone: 707-542-4353
Fax: 707-544-8230

Email: gpajeep@yahoo.com
www.classicmilitaryautomotive.com

Ask for
TERRY O'CONNOR

1941 to 1954 AWD military vehicle sales, restorations & repairs

MVCC FRONT OFFICE

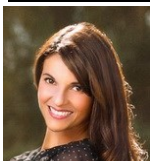

Christina Verissimo, Treasurer
(209) 918-0388
crstna_vrsmo@yahoo.com



John Verissimo, Secretary
(209) 918-0488
istanbull@sbcglobal.net

UPCOMING EVENTS

April 24-29, 2018 Spring Meet Petaluma KOA.

No vendor fee except camping fee.

Contact: MVCC Wagon Master

Jo-Ann Lesser; (408) 238- 8277

mamalesser@yahoo.com

September 2018: Camp Gridley

Butte County Fairgrounds, Hosted by the NRG

www.northernrecongroup.org

September 18-23, 2018 Fall Camp Delta

Second largest annual Military Vehicle gathering and swap meet in the West.

Location Tower Park resort Jelly Stone Park

For reservations, please call Joann lesser

408-238-8277

www.mvccnews.net

November 5, 2017 American Legion Post 237 in Pleasanton CA. Will be celebrating Veterans Day with a Hometown Parade the Sunday before the holiday. The Parade theme this year is Medics of the Military, and we have at least two Medics, one Veteran and one currently serving. Elizabeth C. Freitas Asst. Adjutant- American Legion Post 237 Pleasanton CA

<http://www.americanlegionpost237.org/>
elizabugster@gmail.com

November 10, 2017 9 am to 4 pm Turlock Veterans Charitable Trust. Turlock Golf Course. Please bring MVs for static displays around course. Free food and drink for participants.

Call Lee Smith 209-988-8832

November 11, 2017 The Three Rivers Historical Society & Museum is having our annual living history day this year. We are honoring our service members and veterans. The event is for one day running from 10am to 4pm.

Thomas Marshall, Ph 559-561-2707

www.3rmuseum.org

November 11, 2017 Gustine Veterans Parade.

Downtown Gustine, line up 9 am.

call Don Gomes -209-765-1273

November 11, 2017 Redwood City Veterans Day

Static vehicle display drivers should check in on Broadway between Hamilton and Middlefield.

Vehicle owners will receive a Certificate of Participation. Requested arrival time is between 7 and 8 am, so they can move participants to the staging area before the vendors get onsite.

Ceremony starts at 11 am POC is Chris Cheshire email: ccheshire@yahoo.com

Phone: (650) 703-1113

Please let her know ahead of time if you are coming.

Free doughnuts & coffee for participants.

October 21, 2017 To: All Interested Automobile Collectors. Auto Swap Meet At the Alameda Naval Air Museum. Sponsored by the Early Ford V8 Club & Alameda Naval Air Museum. 6:00 a.m. to 3:00 p.m.

Large two car spaces, Stall price \$30.00, One car for sale space, \$20.00.

All Show Cars or Military Vehicles, Preferred Parking in front of the Museum stairs. Bring a Show Car or Military Vehicle and get a Free Museum entry. All other Museum entry Special day price \$5.00.

No Buyer charge for Swap Meet or parking. Early morning donuts and coffee available \$ 1.00 each,

all proceeds go to support Alameda Naval Air Museum. Food Truck available after 9:00 a.m.

For Information , Please call Larry, A.N.A.M at 510-522-6440 or Mark at 510-432-1532

For mail in Entry Forms, Contact Alameda Naval Air Museum at , 510-522-4262.

Starting next week , Entry Forms can be picked up at Lee Auto Supply on Park St in Alameda.

If you have any questions or have information regarding a meet or activity in your area, contact your regional vice president or any of the officers to let them know. Be sure to visit our website for any last minute activities or changes to activities/events. Please submit information regarding upcoming activities to the newsletter editor at least two months before the scheduled event. All articles must be submitted to the newsletter editor by the 15th of each month.

UPCOMING EVENTS

November 11, 2017 San Jose United Veterans Council of Santa Clara County. Veterans Day Parade, South S.F. Bay Area Saturday November 11th in San Jose Staging area somewhere on Almaden Blvd Normal staging place, is near SAP Center on West Santa Clara Street at Almaden Blvd Abnormal staging place, is further South of West Santa Clara Street on Almaden Blvd Requested arrival time is before 9 am Parade starts 11 am Email for updates / conformations to Kim Sievert vaudevillian@msn.com <http://www.uvscce.org/VetParadeInfo.htm>

November 11, 2017 Petaluma Veterans Day Parade. This Annual North Bay Parade, begins at 1 p.m., starting point at Walnut Park at "D" Street, For info: Scott Rohrs 415-259-8177 recon3rdid@yahoo.com

SMITH CHEVROLET CADILLAC
6th Annual
Honoring Our Veterans Golf Tournament
Benefiting the
TURLOCK VETERANS CHARITABLE TRUST

Friday, November 10th, 2017
at Turlock Golf & Country Club
9:00 Registration • 11:00 Shot Gun Start
Food & Beverages Provided Throughout
the Tournament. Heavy Hors d'oeuvres
& Raffle Immediately Following 4 Person Scramble

\$135 Per Player
Prepaid by Oct. 15th
(\$150 per player after)

*Sponsor Opportunities Available.
Sign Up Your Team Today!*

Call for availability (209) 613-7352
Mail and make checks payable to:
"Turlock Veterans Charitable Trust"
2930 Geer Rd. #154, Turlock CA 95382

Turlock Veterans Charitable Trust is a 501C3 non-profit organization. A portion of your donation may be tax deductible. Please consult your tax advisor. Our 501C3 Tax ID number: 47-5076858

TURLOCK GOLF & COUNTRY CLUB
ESTABLISHED 1924
Turlock Country Club
10532 Golf Link Rd., Turlock, CA



MVCC NEWS STAFF



MVCC Editor Dave Ball

(408) 805-0065 vought@msn.com

Please submit all contributions for publication in the newsletter by email to the editor by the 15 of the month.



Webmaster Sean Nichols

Jetnoise400@hotmail.com

www.mvccnews.net

(775)-424-3813

MVCC STAFF



Andy Shyers East Bay VP
Divisions 510, 925
510-832-4322
mvcc510925@gmail.com

Hello to all in MV'ers in 510/925!

Thought I should introduce myself now that the MVCC VP title is official.

I'm Andy and am new to the MV hobby, but my interest in vehicles and military vehicles is not. Nearly 3 years ago I purchased my first MV, a '51 M37. This purchase was driven by events many decades ago. As a kid I always admired the M37 brush trucks at our local fire department and the darn things imprinted on my brain. Fast forward to the purchase, I've been teaching Auto at San Leandro High for the last 15 years and every year the students and I embark on a project. It seemed that an M37 would fit the bill well, parts were available, it would be something different, hopefully it would be relatively inexpensive, and it would be a great teaching tool due to robust construction (a lack of flimsy plastic throw away parts). As a teaching tool the M37 has been great, but if I knew then what I know now... :)

So we've had the M37 for nearly 3 years and 9000 miles. We've gone through nearly every system on the vehicle. We've also had the opportunity to service another

member's M37 as one of our smaller projects. The M has become one of my teaching tools of choice :). It's also opened up the world of the MV hobby to my family and students. I didn't realize a MV could lead to so many great conversations, friendships, and adventures. So with some good natured prodding from Mike and Randy and a few votes here I am. If you need to get in touch with me my cell is 510-832-4322. Please contact me with any events you know of and I'll do my best to get the word out. In addition we frequently head out to Cars & Coffee at the Blackhawk Museum on the 1st Sunday of the month from 8-10 and then grab some brunch. If your in the neighborhood it's good fun!

Hope to see you soon,

Andy Shyers



Sonny Hanson, No. Bay, East VP
(707) 552-6918 Div. 707,415
sonnyhanson@comcast.net

Hello to all. Fleet week is coming up on October 7 and 8. On the 8th only Red Oak Victory will be serving breakfast at 0900 through 1300 Sunday 8th. Bring an MV, Classic Vehicle, Hot Rods, Motorcycle 1900's through 1960's and get breakfast for \$5.00 and get to park VIP next to the ship in a secure area. Come as you are for \$10.00. Kids are \$5.00. You get Pancakes, Sausage, Bacon, Eggs anyway you want as long as they are Scrambled, Apple Slices, Orange Juice and Coffee. Eat in the Crews Mess or on Deck and then take a Self-Guided Tour the ship free. I plan to be there for fleet week. I hope to see you there. You can email me with your questions.

sonnyhanson@comcast.net

You can also go to www.redoakvictory.us

Your North Bay VP east.

Sonny Hanson
Your MVCC North Bay VP east
From my non-mobile command center



Dave Porter, Northern Region VP
Divisions 530 & 916
dnporter56@comcast.net
530-677-5115

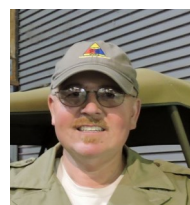

Don Gomes, Central Valley VP
Divisions 209,559,661,760
(209)765-1273
caddymanwestside@yahoo.com



Kim Sievert, South Bay VP
(408) 253-9469
vaudevillian@msn.com
Divisions 408, 669 North 650

MVCC STAFF



Jack Valenti, Central Coast VP
Divisions 831, 805 408 south
LRDG@PRODIGY.NET
831-595-3487

Sorry that I missed the General meeting at Tower Park, unfortunately I had a conflict with an unscheduled doctor's visit, nothing to worry about.

I thought I had all of my plans for October and November all worked out but things keep changing; almost faster than I can change my calendar .

1. Oct 1st – 9th - San Francisco Fleet Week. – <https://fleetweeksf.org/> I won't be attending any of those events, as I have friends coming in from New Zealand to stay from the 6th to the 11th
2. Oct. 12th – 14th - After my guest leave, I must take my wife to the "Pacific International Quilt Festival" in Santa Clara. I don't imagine that many of you will be putting that on you schedule.
3. Oct. 17th – 24th – Donna and I are going to Las Vegas.
4. Nov 11th – There is a bevy of events all over the state for us to participate in. Salinas has one that I have attended in the past. But will miss it this year. <https://www.salinasveteransparade.org/> as I made plans to attend the one in San Jose along with T-8 and then a static display at Santana Square. But something has come up and I'll be in Reno from the 9th to the 13th. I'll be looking for someone to be POC for the Salinas event.
5. After that it's the holidays....

Jack

PS. Our local Lions Club had a Motorcycle Show on Sept. 24th. Rumor has it that someone in the MVCC took a trophy for a Military 1941 Indian. I'm sure he'll be bragging about it.



Above Pictures Taken Tower Park Fall 2017
Ed.

MVCC STAFF



Scott Rohrs, North. Bay West VP
Divisions 707 & 415 west
415-259-8177
recon3rdid@yahoo.com

Hello North Bay West and beyond,

This is my first article since the June newsletter. As many of you know this is the busiest time of year for me, and my trade (firefighting).

With that being said I have been able to participate in a few events: the 4th of July Parade in Napa and the Skip Long Car show in Yountville. Those were both great events! I also have been tinkering on the WC 3 (not as much as I would like though).

I hope you all got the word about the new PBS/ Ken Burns documentary on Vietnam. This should be a good one! Ken does such a good job with his documentaries. I am really looking forward to this program.

By the time this comes out we would have had our fall event at Jellystone Park (formerly and always will be Tower Park). As we all know there are many Veteran's Day events going on in November and we will all be getting ready for those events and parades.

I would like to take this time to address some issues that have been bothering me of late. That is the lack of participating, contributing, and a lot of negative talk about the direction of the club! This is very troubling to me because I know how much effort goes into the running of this club. I know that our membership is at its highest levels and that this is the largest MV club in the World. Yet we still have the same group of about 20 folks doing all the legwork. Many officers are doing double duty. With any club there are always folks that aren't happy. I GET IT! We are in a time of transition for the club. Meaning most of our older members are trying to pass the torch to our younger members. This is always hard. Add the fact that Tower Park changed ownership and the new venue at KOA Petaluma had many inaugural issues, it has been rough! Believe me when I say that we as officers hear you and we are trying to fix these issues! Where is the loyalty and the faith though folks?! Help us help the club make this spring event GREAT AGAIN! I see fracturing and discontent for the leadership and the club as a whole. This is not the way you make things better. By getting on forums and slamming the club and its members. As for the vendors, many of you have built your businesses on the backs and wallets of this club! Again where is the loyalty and faith? These are your friends, or is it all about the all mighty Buck? If any of you know me, I do speak my mind, but I rarely do this sort of thing in a public setting (especially in print). I believe this needed to be addressed. I thank all of the members who repeatedly are there to lend a hand. You know who you are and you are appreciated!

I believe we do have the best MV club in the world. It is our membership that makes it the best!

I would love to hear from you and your concerns.

Scott Rohrs North Bay West VP 415 259 8177





Above and bottom Pg. 8 pictures are from Capital Airshow 2017 at Mather Airport, Sacramento. MVCC/ Foothill Vintage Jeep Group members attended on Saturday, September 9, 2017. Ben Hovis, Dennis Deck, Dennis Larson, Randy Payne, Tim Buescher, Doug O'Neil, Pat Walker, Rich Horvath. GTB: Dave Porter. Pictures: Dave Porter

Military Vehicle Collectors of California Merchandise



The 2017 MVCC Petaluma Meet Tshirt.

"Olive Drab"

This is a limited run Military Vehicle Event Tshirt, once they are gone they are gone! Sizes S,M,L,XL, XXL

Email or text for sizes still available!

\$20.00

The 2017 MVCC Petaluma Meet Tshirt

"Kaki" color...

\$20,00

These are limited, check for sizes



Limited Run 40th Anniversary MVCC Patch. This is a 4 inch patch, looks great, I bought 2 myself!

\$7.00 each



Limited Run 25th Anniversary MVCC Patch

This is a 4 inch patch, looks Awesome!

\$4.00 each



MVCC Patch

3 1/2 tall

\$3.00 each

This MVCC magnate is perfect for those who aren't sure they want a perminate sticker on their cars or military vehicles!



MVCC magnate

3 inch tall

\$2.00 each

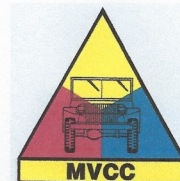

MVCC sticker

3 inch tall

\$2.00 each

MVCC Stickers are a GREAT WAY to show everyone you are a MVCC Member, put them on your military vehicles or your automobiles!



MVCC sticker

2 inch tall

\$1.00

For availability email istanbull@sbcglobal.net or text (209)918-0488

Mail payment to Christina Verissimo
Treasure MVCC
850 Elm Ave
Gustine, Ca. 95322

The MVCC Antenna Guidon/Pennant is still available \$25.00. These are great for your flag pole or your military vehicle antenna!

These little stickers are great for car windows, tool boxes, gas cans etc...

Shipping; Give us your zip code and we will give you a shipping cost.

We don't have a Quartermaster yet so Don Gomes and Myself (Johnny Verissimo) are filling in as best we can, thank you for your patients...!

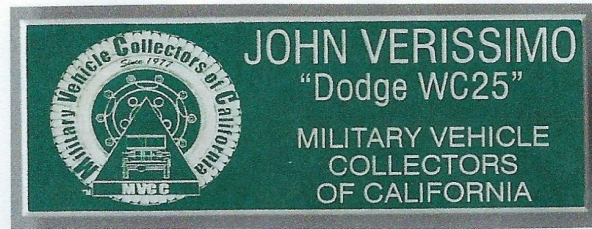

Military Vehicle Collectors of California Name Badges are one way of knowing who the other person is at an event. As I get older I find that I am better with faces than I am with names, so many times I will casually look over to the persons name badge to make sure I get their name right, its kinda like a life savor for myself. But in all seriousness, MVCC name badges are a GREAT way to Represent yourself as a MVCC Member to the public and to other members.

Places to wear your name badges are parades, MVCC Spring Meet, MVCC Fall meet, military fundraisers that require your military vehicle, fly ins at airports that you will be taking your vehicle to, as an MVCC volunteer at an military event, when you are being interviewed by your local news channel or attending a military vehicle social, or attending the MVPA National Convention and Im sure there are other places and events you could wear it to.

You can order one for yourself and your wife/significant other if he/she is an associate member. Im glad to see more and more members buying and wearing them!

The cost of the MVCC Badge is \$10 each, that includes shipping to your house. They are custom engraved so they never wear out, these badges will last you the rest of your life!

I've kinda modified them a little by adding the town your from under your name. On mine, which I did years ago I put my favorite vehicle that I own, my Dodge WC25. Because I did that I will do the same for others if there is space. The badge comes as seen in the picture above, your name, then underneath your town/city.

If you would like to purchase one just let me know either via email or phone call: Johnny Verissimo istanbull@sbcglobal.net or (209)9180488. You can mail payment to MVCC Secretary, 850 Elm Ave, Gustine, Ca. 95322. Please write clearly your name and town you are at.

Regards,

Johnny Verissimo

MVCC BUSINESS MEMBERS

Ron Fitzpatrick
JEEP PARTS



1022 Newland Road
 Central Point, Oregon 97502

sales: 800-600-5337
 tech: 541-830-3030
 fax: 541-830-5337

RON FITZPATRICK
 sales@g503.com
 ron@g503.com

www.rfjp.com www.g503.com/parts

★ ★ ★ ★ ★ ★ ★ ★

Dc Truck parts 541-772-8992

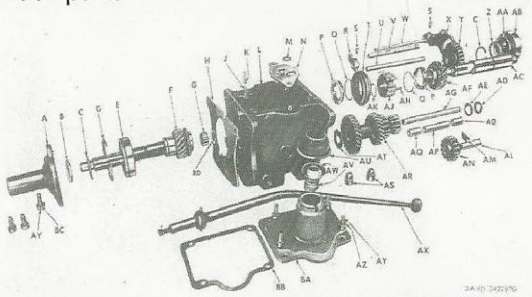

Dave Cirillo
 dctruckparts@msn.com

EXPEDITION IMPORTS
Get Out of the Ordinary!

Scott Ingham
 President

scott@expedition-imports.com
 www.mpttires.com
 www.expedition-imports.com

1335 Lemon Street
 Vallejo, CA 94590
 Tel 707.643.6757
 Cell 707.319.7252
 Fax 707.643.2998

Ray Del Pino  DMV License #VV17807

ANTIQUE • CLASSIC • MODERN
VIN NUMBER VERIFICATION
 AT YOUR LOCATION IN SOUTHERN CA
 TRUCKS, TRAILERS, SPECIAL MOBILE EQUIPMENT
 MOTOR HOMES, AND CARS
 DMV RUNNER SERVICE
 CLASS C DRIVEAWAY - GETAWAY DRIVER
 15708 E. Grovecenter St. • Covina, CA 91722
 Cell: (626) 391-2167 • Home: (626) 814-2196

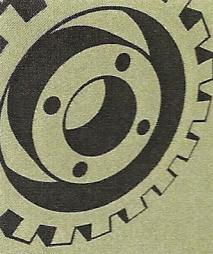

DOWNTOWN TRUCK PARTS

NORMAN GORELICK

20830 KINGSBURY ST
 CHATSWORTH CA 91311

1-818-709-3676
 MACK6X6@AOL.COM



CARSON PLAINS SURPLUS & STORAGE
 Military Surplus, Military Vehicles, Storage, Firewood
JON BIRCHEFF
 Owner



P.O. Box 1289
 70 S. Rainbow Dr
 Dayton, NV 89403
 Cell: 775-246-7186
 Fax: 775-241-7142
 jon.cpsands@gmail.com
 www.cpsands.com

Smith Chevrolet Cadillac, Inc.
"Where service comes first since 1926"
 1601 Auto Mall Drive
 Turlock, CA 95380



Lee C. Smith
 Owner
 (209) 632-3946
 (209) 988-8832 Cell
 (209) 667-7157 Fax
 leesmith@SmithChevroletCadillac.com
 smithchevroletcadillac.com



Find us on facebook.

Visit Online Store @ www.rfjp.com

Ron Fitzpatrick

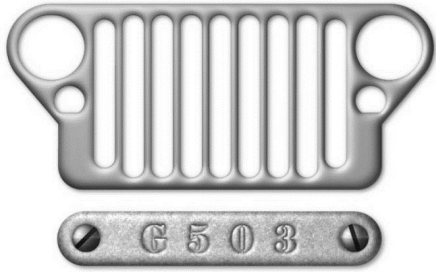

JEEP PARTS

SEE OUR WEBSITE @ www.rfjp.com



(541) 830-3030 (local) * (541) 830-3031 (tech)
sales@g503.com (541) 830-5337 (fax)
M-F 8 a.m. till 5 p.m. West Coast

800-600-JEEP (5337)

New not Rebuilt



A1223 Carter WO
Carburetor \$310



A8180 - LN Speedometer
w/ trip odometer \$100
MB or GPW

*Note: These have 1 mph incremented
dials with the correct luminous paint on
needles and the 10 mph and 20 mph
markers*



Available markings
GPW \mathcal{F} GPW8505
or
MB 637052

639992 Water Pump
MB or GPW \$90



A8180 - SN Speedometer
w/ trip odometer \$100
MB or GPW

A8323 Fuel Pump
w/ Primer Lever \$60



A847 or A838
Tie Rod End Kits \$15



A1339
Hub Puller \$15

GPW w/ script \mathcal{F} available

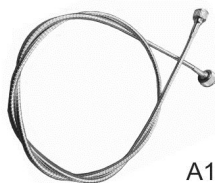

A1267 Speedometer Cable
With metal Housing \$15

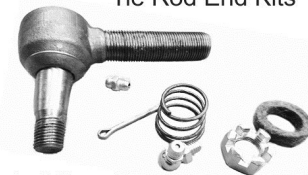

Available markings
GPW \mathcal{F}
or
MB TP

*Each Kit includes cup, spring
felt washer, cotter pin, castle
nut and 2 zerk fittings*

FREE SHIPPING*

Online Orders Only thru August 31st, 2017

* restrictions apply: no phone orders, continental U.S. orders only,
\$200 minimum order, oversized and freight orders excluded

CLASSIFIEDS

For Sale: U.S. Military Jeep Radio Sets. MB/GPW: SCR-510 (BC-620), SCR-284 (BC-654), and SCR-610 (BC-659). M38, M38A1, M422/A1: GRC-7 (RT-68+R110+ RT-70), PRC-10, VRC-10 (RT-68), and VRC-18 (RT-68+R110). M151/A1/A2: VRC-53 (PRC-25) Complete and ready to install. Includes: Transmitter/Receiver, Power Supply (s), Radio/Power Supply Connector (s), Auxiliary Receiver (if applicable), Vehicular Shock Mount, Weather Cover (if applicable), Loudspeaker and/or handset, Antenna Mast Base Bracket, Antenna Mast Base, Antenna Sections, Vehicular Power Cable, and Antenna Cable. U.S. Military Man-pack Radio Sets. WW2: SCR-536 (BC-611), SCR-300 (BC-1000), SCR-510 (BC-620), SCR-284 (BC-654), and SCR-610 (BC-659). Korea: PRC-6, PRC-10, TRC-20/RT111/(BC-659). Vietnam: PRC-25. Including (where applicable) : Handset, Carrying Harness, Both Antennas, Accessory Belt Pouch, and Power Cable and Hand Crank Generator. U.S. Military Telephone Sets. WW2: BD-71 Field Telephone Switchboard with 6 EE-8 Field Telephones and Spool of Communication Wire, EE-8 Field Telephone, and TP-9 Field Telephone. Vietnam: Spool 2 Line Communication Wire. U.S. Military Fixed Radio Sets. WW2: SCR-520 (BC-659). Including Transmitter/Receiver, RA-120 110V Power Supply, MD-22/URA11 Modulator, Microphone, and Loudspeaker. Korea: RT-68. Including Transmitter/Receiver, PP-1175A/SR 110V Power Supply, Handset, and Loudspeaker.

Chuck Heindell, 530-282-6297,

Or email: cazamel@hotmail.com. 9-17

For Sale: 1952 Willys M38A1 Jeep This is a project Jeep and has many of the original parts. Seats front and rear need pads and canvas. Still 24 Volt. Engine ran a year ago but rough. Missing top bows and batteries. Has tow bar and is towable. Surface rust no rot \$4500 Dave 408-805-0065 12-17

For Sale: 1943 GTBS with crane and winches and both are frozen and engine is civilian flat head six .. also have parts from other GTBS's for sale ..asking \$2200 OBO For truck & crane Don . 209-765-1273 or email for me photos caddymanwestside@yahoo.com 11-17 Picture Below



For Sale: 1977 Dodge M880: 4 wheel drive, rebuilt larger dodge engine w/ 4 barrel carb, upgraded muffler system, heavy duty truck tires, shock absorbers, over load springs and sway bar, electric winch, CUCV grill guard, power steering, spot light, black out lights, siren, roof rack, mounted tow bar, reupholstered seats, antenna mount, and power supply for PRC 25/77 radio. This truck is in excellent condition. It has just been serviced and has a new CA smog certificate. A comfortable military vehicle with lots of power. Call Chuck Billings 415 717-9904 or e-mail drcrbillings @comcast.net. 11-17

Classified Ads are free for military vehicle related items and kit for MVCC members. Your ad will run for three issues. Your editor will only except ads in writing. Please submit your ad by email: vought@msn.com or by post to: MVCC Editor: 18549 Paseo Tierra St. Saratoga Ca. 95070. Please print clearly and include contact info and price. Please submit ads by the 15th of the month. If you want to make changes to your ad including extending or cancelling your ad, you must notify your editor in writing. The MVCC is not responsible for omission's or Incorrect wording and or spelling. The MVCC reserves the right to edit ad copy for space. Please send payment for paid ads to: LK Viola, Email: sec-treasurer@mvcnews.net

Ad prices: full page \$45 Half page \$35 Quarter Page \$20 Business Card \$5 per issue

CLASSIFIEDS

For Sale: M-151-A2 (MUTT) Barn Fined, ROP's Kit Installed - has all webbing, Great tires, body uncut, New Electrical harness front and rear, All fluids flushes, New hoses, new fuel sending unit, Starts up right away, New batteries, All seats and covers, Current registration, Heater kit installed, New exhaust system, Antenna mount corner bracket with antenna base, most new Gauges, Great find. Picture Below.\$17,500
Brad Carrott (831)345-0372
Bradcarrott@gmail.com 9-17



For Sale: 1942 MBT very little rust tub in great shape . Title in hand and currently tagged also have all parts to put back to original . Has tail gate but repro rear panel to Replace comes with trailer \$1399
Don 209-765-1273 Picture Below 11-17



For Sale: 1952 M-38 A-1 Willy Jeep, lots of new parts: fuel tank cleaned, new fuel pump, new carb, new electronic distributor, new spark plugs and wires, new muffler, new radiator hoses, new antifreeze, oil and filter change, new tow bar, new seat covers, has back seat. Comes with extra parts, and tires. Runs very good, has Ca. historical plates that are current. Serve in Korea war, then surplus to Universal Studios, was on Mash TV series: movie prop!! 12 Volt conversion, with alternator, New battery, solar charger, Needs wiring harness installed, comes with painless wiring harness. Might need steering box rebuilt ? Have receipts on all new parts, that were put on. Health and family emergency forces sale of this jeep. Have over \$4,000 invested new parts. Located in Murrieta, CA. 92562. \$6,500 Firm Call Jim 760-214-0908 11-17

Wanted: Parts for RT-524, Radio Remotes (2), Radio Control C-2299/VRC, 524-Radio Control Cable CX-4723U, Antenna Wire CG-3855/VRC. POC- Sonny Hanson 707-552-6918 or Bob Taylor 707-953-7242 11-17

Wanted: Looking for a Restored 1941 Dodge WC 1 I'm too old to do another Restoration, Looking for maybe an older restored truck that needs an appreciative home Contact: Tom Furrer 10-17
email: uacg@sonic.net Phone: 707-481-2264

Wanted: WWII M-8 Armored Car in good running condition. Please contact Steve K at 714-299-4593 in Chino Hills, California 9-17

Wanted: M-345 10-ton 2 axle trailer in good Condition. These trailers were made in the 1960's and 1970's.
Contact Jay 707-495-1871 pmmkin@hotmail.com 9-17

MVCC Election Ballot Stats 2017

The ballots were opened and counted on August 25th by myself and MVCC member Claude Mourey. Sixty-three pieces of mail were received by the election deadline. Twelve pieces contained two ballots. All ballots appeared authentic and we believe represented MVCC member and Associate member ballots being returned together. Total ballots counted were 75. An additional 20 pieces of mail were received after the deadline. These pieces were not counted, so are not reflected in the totals. With only three votes written in, the results are quite conclusive and no other vote count was deemed necessary.

All ballots, counted or not, actual tally sheets, record of mail received by date and final tally tabulation sheet will be submitted to MVCC Secretary John Verissimo for the club archive. Any member desiring to review this material should direct their inquiries to him.

Randy Canova August 25, 2017 2017 Election Chairman

MVCC 2017 ELECTION RESULTS

1. President

Dave Ball

2. Secretary

John Verissimo

3. Treasurer

Christina Verissimo

4. Central Coast Vice-President

Jack Valenti

5. Central Valley Vice-President

Don Gomes

6. East Bay Vice-President

Andy Shyers

7. North Bay East Vice-President

Sonny Hanson

8. North Bay West Vice-President

Scott Rohrs

9. Northern Region Vice-President

Dave Porter

10. South Bay Vice-President

Kim Sievert



Above Pictures Tower Park Fall 2017

Ed.



Military Vehicle Collectors of California
*Dedicated to the acquisition, restoration, preservation, safe operation,
 Public education and display of historic military transport*

WE WANT YOU
TO JOIN / RENEW
YOUR
MVCC
MEMBERSHIP!



INVOICE

Life Members should disregard this notice. THANK YOU for your support! If you have already renewed, THANK YOU! please check the date code on your newsletter mailing label and membership card. Is your expiration year "2017" ? If it is this means your membership expires January 1, 2017. Please renew your membership.

Please enter an e-mail address for possible future methods of communication. If you list MV's or related hobby interest, it will show up on membership lists the MVCC Officers receive. Sometimes we want to contact members with certain MV's about displays or movie work. Note that you may opt-out of having contact or hobby information published in the next Member Directory booklet. This is your application. Separate it from the newsletter, or copy it, fill it out, and fold it put it in an envelope with your check inside, apply postage, and mail it. Simple!

* = required fields, please PRINT

*Name _____ MVPA # if applicable _____

*Address 1 _____

Address 2 _____

*City, State, ZIP _____ Country _____

Home phone _____ Cell phone _____

E-mail address _____

I DO / DO NOT want my contact information in the Directory (circle one)

List military vehicles you own (year, make, model) and/or related hobby for the next Directory. Help those with similar interests find you. Use separate sheet if necessary.

MEMBERSHIP (check one) Term is Jan 1 – Dec 31

\$35 regular member for one year only newsletter mailed

\$85 regular member for three years newsletter mailed

\$25 regular member for one year only newsletter online only

\$60 regular member for three years newsletter online only

\$60 business member (includes one, 2"x 3.5" ad in each newsletter (business card). No voting rights. A business member may also hold another class of membership

ASSOCIATE MEMBERS (spouse or significant other, and/or children under 18). Includes membership card. Only spouse has voting rights. One newsletter delivered per household

_____ Associates @ \$5.00 each per year, badge \$12.50

New members receive one badge. Associate Badges and replacement badges \$12.50 ea.

Amount enclosed _____

Print associate name and relationship to member

Christina Verissimo, c/o MVCC Treasurer,
 850 Elm Street Gustine, Ca 95322
 Make checks payable to the MVCC

*I DO / DO NOT want my MVs or hobby interests listed in the next Directory (circle one)